

# Acoustic Level Sensor

RL

## RL Operating Instructions

- **Acoustic Level Measurement**
- **Reliable Accuracy in High Dust Environments**
- **Performs in Powders & Solids**



**BINMASTER**  
www.binmaster.com

---

# Contents

<b>1</b>	<b>ABOUT THIS DOCUMENT</b>	<b>3</b>
1.1	SYMBOLS IN USE	3
1.2	FOR YOUR SAFETY	3
1.3	STORAGE AND TRANSPORT	4
<b>2</b>	<b>RL™ OVERVIEW</b>	<b>5</b>
2.1	THEORY OF OPERATION	5
2.2	WIDE APPLICATION RANGE	5
2.3	ADVANTAGES	5
<b>3</b>	<b>PHYSICAL INSTALLATION</b>	<b>6</b>
3.1	LOCATION AND POSITIONING GUIDELINES	6
3.2	SCANNER ORIENTATION	7
3.3	SITE PREPARATIONS	8
3.4	ASSEMBLY AND MOUNTING	9
3.5	WIRING	11
<b>4</b>	<b>CONFIGURATION</b>	<b>15</b>
4.1	LOCAL USER INTERFACE	15
4.2	SWITCHING ON THE SCANNER	16
4.3	MAIN MENU	16
4.4	BASIC CONFIGURATION	17
4.5	OUTPUT SETTINGS	21
4.6	DISPLAY SETTING	22
4.7	FALSE ECHO MAPPING	22
4.8	DEVICE INFO	23
4.9	DEVICE RESET	24
<b>5</b>	<b>DIFFERENT CONNECTION METHODS</b>	<b>25</b>
5.1	4-20MA CONNECTION	25
5.2	HART COMMUNICATION	25
5.3	RS-485 COMMUNICATION	26
5.4	COMMUNICATION USING THE 3DLINKPRO	26
5.5	TCP/IP COMMUNICATION	26

---

<b>APPENDIX A: ACCESSORIES.....</b>	<b>27</b>
INSTALLATION FLANGES .....	27
NECK EXTENSIONS .....	29
HEAD-BODY SEPARATION.....	30
CABLE EXTENSION .....	31
CABLE GLANDS .....	31
<b>APPENDIX B: MAINTENANCE.....</b>	<b>32</b>
<b>APPENDIX C: RECOMMENDED TOOLS .....</b>	<b>33</b>
<b>APPENDIX D: SPECIFICATIONS .....</b>	<b>34</b>
TECHNICAL DATA.....	34
DIMENSIONS .....	37

---

# 1 About this Document

This operation manual provides detailed product related information, installation, setup and operation instructions for RL2000. The manual is designed for trained personnel. Please read it entirely and carefully before unpacking and installing the products.

## 1.1 Symbols in use

The following symbols indicate different sections of additional information as follows:



**IMPORTANT:** An indication for additional information, tips, hints or an indication of helpful additional knowledge.



**WARNING:** Indication of a potentially dangerous situation, which could result in serious injury to persons and/or damage to the RL.



**EX APPLICATION:** An indication of special instructions relevant to installations in hazardous locations.

## 1.2 For your safety

### Authorized personnel

All operations described in this manual must be carried out by authorized, trained personnel only. For safety and warranty reasons, any internal work on the scanners must be carried out by manufacturer-authorized personnel only.

### Warning about misuse

Inappropriate or incorrect use of the scanner may result in hazards and application-specific malfunctioning such as vessels overflow or damage to system components through incorrect mounting or adjustments.

If the RL is used in a manner not specified in this manual, the protection provided by the RL will be impaired.

### General safety instructions

The RL is a high-tech device requiring strict observance of standard regulations and guidelines. The user must strictly follow the safety instructions in this operating manual. Local and national electrical codes and all common safety regulations and accident prevention rules should be considered during installation as well.

## CE conformity

The RL conforms to CE's EMC and NSR standards. CE conformity is as follows:

<b>EMC</b>	<ul style="list-style-type: none"><li>▪ EN 61326-1: 2006</li><li>▪ CISPR 11: 2003 Class A</li><li>▪ IEC 61000-4-2: 2001 Air Discharge, 8kV</li><li>▪ IEC 61000-4-3: 2002 80-1000MHz, 1V/m; 1.4-2GHz, 1V.m; 2.0-2.7GHz, 1V/m</li><li>▪ IEC 61000-4-4: 2004 Power Lines: 1kV; Signal Lines: 0.5kV</li><li>▪ IEC 61000-4-6: 2004 0.15-80MHz 1VRMS, 80% A.M. by 1kHz Power &amp; Signal Lines</li></ul>
<b>NSR</b> (73/23/EWG)	<ul style="list-style-type: none"><li>▪ EN 61010-1: 2001</li></ul>

## FCC conformity (EMC)

FCC Part 15, Sub-part B, Class A.

## Safety information for Ex Areas



**EX-AREAS:** Please note the Ex-specific safety information for installation and operation in Ex areas. These safety instructions are part of the operating instructions manual that comes with Ex-approved scanners.



**WARNING:** Substitution of components may impair Intrinsic Safety.

**WARNING:** For preventing ignition of flammable or combustible atmospheres, read, understand and adhere to the manufacturer's live maintenance procedures.

## 1.3 Storage and transport

The scanner is protected by special packaging during transport, and is guaranteed to handle normal loads during transport.

---

## 2 RL™ Overview

### 2.1 Theory of Operation

The APM RL™ is the only device available which delivers accurate measurement of bulk solids and powders – regardless of material type, product characteristics, storage silo type, size, bin or container, and harshness of the storage environment. The product incorporates APM's unique dust-penetrating technology to achieve an unrivalled degree of process measurement and inventory control.

The RL™ includes an array of three antennas that generate low frequency acoustic signals and receive echo signals from the contents of the silo, bin, or other container type. Using these antennas, the unit measures not only the time/distance of each echoed signal but also its direction.

The built-in Digital Signal Processor samples and analyses the echoed signals and produces accurate measurements of the level.

### 2.2 Wide Application Range

The RL™ measures practically any kind of solid material, stored in variety of containers, including large open bins, bulk solid storage rooms, stockpiles and warehouses, and many other challenging applications that were not possible until now. The sensor can measure ranges of up to 70m (230ft).

### 2.3 Advantages

- Service and maintenance-friendly, Non-contact measuring principles, the RL™ is highly easy to service and maintain
- The only available device for solid volume measurement applications
- Suitable for measuring all solid materials (including ones with low dielectric constants)
- Operates in dusty and moisture environments
- Self-cleaning antenna
- The most reliable sensor available - includes 3 transmitters and 3 receivers

---

## 3 Physical Installation

This chapter describes the necessary steps for proper installation of the RL beginning with important pre-installation considerations such as environmental conditions, correct positioning and orientation, through the mounting and configuration process.

### 3.1 Location and positioning guidelines

Choosing the proper location to the RL™ should consider every aspect of the vessel and contained materials, including the vessel shape and dimensions, type of material and angle of repose, location of filling and emptying points, maximum level of material, internal construction and moving part and any other consideration which may possibly affect the scanner performance.

#### Moisture and water condensation

 Use the recommended cable gland and tighten the cable connection. For additional protection against moisture, lead the connection cable downward in front of the cable entry. Rain and condensation water can thus drain off. This applies mainly to mounting in areas where moisture is expected (e.g., by cleaning processes), or on cooled or heated vessels.

#### Measuring range

The measuring range is set in the scanner and defined by silo dimensions and the full and empty calibration levels. These levels set the 100% and 0% values relatively.

The scanner measurements are calibrated to the top of the body. If the scanner is lowered, or mounted with neck extension or head-body separation, it is important to adjust all measurements to the top of the body.

 **NOTE:** If the material level reaches the antenna, build up could form inside the horn over time and cause measurement errors or damage to the membranes.

**NOTE:** the RL™ has a 500mm (20") of dead zone (or blanking zone).

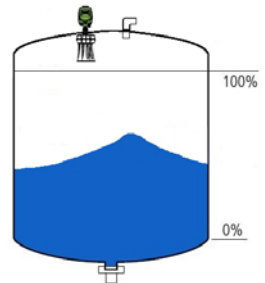

#### Pressure

The process fitting must be sealed in the case of a low pressured vessel. Before usage, verify that the sealing material is resistant to the stored medium. The maximum allowed pressure (stated in *page 34: Appendix D: Specifications*) is indicated on the type label of the sensor.

## Installation location

Choosing the proper installation location for the RL is an important part of the installation process. A Wrong location may result in erroneous measurements or loss of performance.

The following factors must be taken into consideration while choosing the installation position: vessel dimensions, filling and emptying point locations, internal structure or support and other restrictions related to vicinity to noisy devices (such as electrical motor) and any other element which may affect the proper operation of the scanner.



**IMPORTANT:** The RL cannot be mounted at a distance smaller than 500mm (20") from the side wall or filling point.

Installing the RL at the center of the vessel is not recommended, since the perfect symmetry from all sides toward the scanner may affect the echoes distinction.

## 3.2 Scanner Orientation

### Mounting direction

Mounting of the RL at a specific direction is important. The ridge on notch on the top of the thread (representing antenna no.1) should be center of the vessel.

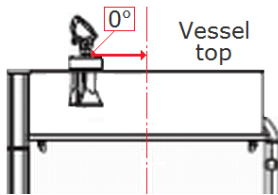

Mounting direction

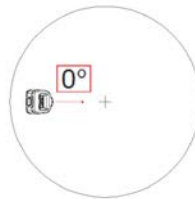

0° indication toward center

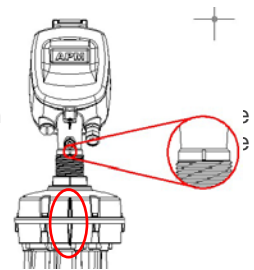

The 0° label location

### Standpipe mounting

When mounting the scanner using a standpipe part it should be assembled and positioned at a height that leaves at least 10mm (0.4") out of the standpipe, for the antenna end protrudes, as shown in the figure to the right.

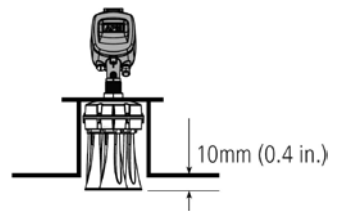

**IMPORTANT:** Any obstruction as well as rails, frames or support beams should never interfere with the acoustic beam transmitted and received, as shown in the figure to the right.

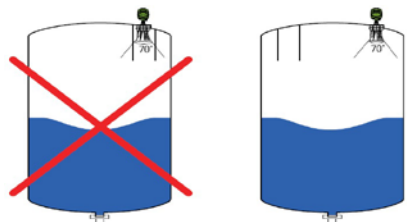

Wrong

Correct



## Inflowing material

Do not mount the RL in or above the filling stream, not too far from the stream, and not in the direction of the filling stream in case it is in diagonal, to avoid damage to the scanner from the flowing material. The scanner should be located with a clear line of sight to the top of the material at high levels, not to be affected by the filling stream or the noise it creates.



## Fitting

The fitting area should be prepared to maintain the horns/antennas vertically positioned to the ground, as shown in the figure.

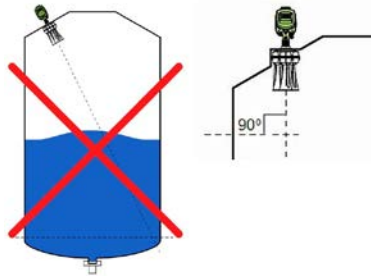

Wrong

Correct

## 3.3 Site Preparations

Before installing, make sure the following preparations have been completed.

### Power

- Connecting the RL chassis to the facility grounding.
- A 24VDC (1.5 Watt) power supply must be prepared and ready to use near the scanner mounting location.
- The RL is a 4-Wire device. The voltage supply and data output (4-20mA) are carried along two separated two-wire connection cables.

### Communications

- Route communication cables in proper conduits and use a proper cable type.
- The cable used for RS-485 should be of twisted-pair type, shielded, with 120 Ohm impedance and rated for RS-485 communications.
- The cable used for 4-20mA should be rated for analog signals, twisted-pair, low resistance and shielded.

## 3.4 Assembly and Mounting

### Package Contents

The supplied package includes:

- RL sensor
- Documentation
- CD with the 3DLevel Manager software and marketing materials
- Cable glands accessory kit
- Ex-specific safety instructions (with Ex versions)
- Certificates if applicable

### Included components

The RL includes the following components:



RL Body



RL Head

- RL Body: Includes three antennas, transducers and temperature sensor. The flange is mounted on the body and tightened to it using the supplied nut.
- RL Head: Includes the electronic board with LCD display and all wiring terminals. The Head is mounted on the body.

### Flange preparation

Prior to the installation of the RL, an installation flange should be prepared. The flange must have a 52mm (2.05") hole for the scanner body thread insertion.

APM provides two types of standard flanges. Please refer to *page 27: Appendix A: Accessories* for flange specifications.



### Installing the Flange

- 1 Verify existence of the O-Rings on the neck tube and the body remains in place as shown:



- 2 Use an adjustable 18" wrench to untighten and remove the nut from the neck tube.



- ③ Place flange over the neck tube, insert until placed as shown:

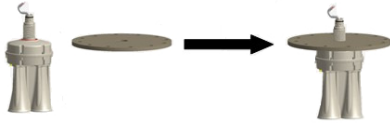

- ④ Replace the nut and tighten it over the neck tube to the flange, using an adjustable 18" wrench.

Make sure the scanner is well tightened to the flange, for vibrations prevention and proper sealing.

When mounting the scanner body and flange to the silo standpipe make sure the scanner is facing the center of the silo as described in *Scanner Orientation on page 7*.



## Installing the Scanner Head

- ① Unpack the scanner head.

Untighten the four screws of the housing rear panel using a 4mm hex key, and remove the rear panel. The screws are of captive type and will not fall off.

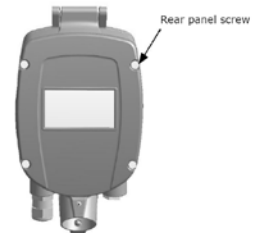

- ② Remove the cable clamp located at the bottom inside the scanner as shown.

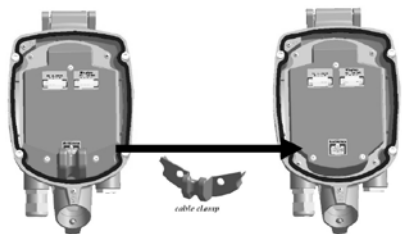

- ③ **Gently** insert the antenna cable through the scanner head. Make sure not to damage the (white) cable connector. This connector connects the transmission signal from the electronic board to the transducers. Damage to the connector or to the wires will result with malfunctioning operation of the scanner.

- ④ Insert the scanner head onto the neck tube.



**IMPORTANT:** When inserting the scanner head onto the neck tube, make sure to push the head all the way down until it fully contacts the top of the neck tube.

**NOTE:** It is recommended to lubricate the O-Ring on the neck tube prior to installing the scanner head. This makes it easier to insert and properly locate the scanner head over the tube neck.

**NOTE:** The RL head may be installed in six different positions.

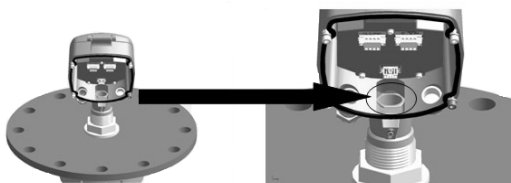

- ⑤ Tighten the front screw using a 4mm hex key and a 13mm wrench.



- ⑥ Replace the cable clamp back to position, between the antenna cable and the electronic board.

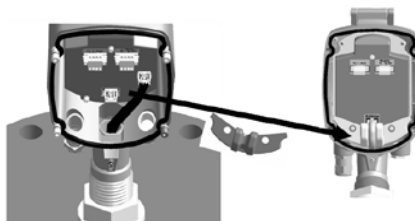

- ⑦ **Carefully** connect the antenna cable connector back to the electronic board as shown.

This connector allows the transmission signal from the electronic board to the transducers. Damaged connector or wires will result with malfunctioning operation of the scanner.

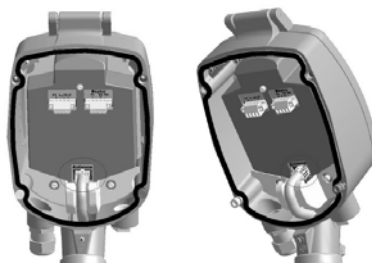

- ⑧ Leave the scanner open at this stage in order to complete the wiring.

## 3.5 Wiring

The RL can be connected in different modes and configurations for different external systems such as PLC or DCS and communications on RS485, ModBus, and HART and also to RS485 bus converting adapters to communication gateways such as 3DLinkPro for

GMS or GPRS data relay and TCP/IP gateway. For in-depth details and explanations on wiring and communication, refer to *page 25: Different Connection Methods*.

- Use 8-13mm (20-24 AWG) diameter cables to ensure proper and effective sealing of the cable gland entry opening.
- Select a cable suitable for application (indoor or outdoor) and safety certified according to national regulations.

## Communications



**NOTE:** If electromagnetic interference is expected, usage of a screened and twisted wired cable is recommended for the signal lines, which should be connected to the ground reference.



**CAUTION:** Always observe the following safety instructions:

Connections must be made only in the complete absence of line voltage.

If over-voltage is expected, overvoltage arresters should be installed.

Use only a safety-certified power supply with dual insulation between the primary and output for powering the unit. The power supply output rating must be limited to 20-32VDC, 1A for a single RL device, and not to be connected to a DC distribution network.



In hazardous areas you should take note of the appropriate regulations, conformity and type of approval certificates of the sensors and power supply units. Refer to the printed safety manual provided with the ATEX/FM approved RL.

## Power Supply

For power supply specifications, refer to *page 35: Appendix E: Specifications for full details*.

4...20 mA/HART 4-wire: The power supply and signal current inputs must be carried over two separated pairs.

## Connection Procedure

- 1 Untighten the four screws of the scanner housing rear panel and remove the rear panel. The screws are of captive type and will not fall off.

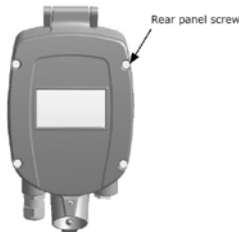

- 2 Loosen the compression nut of the cable gland entry.

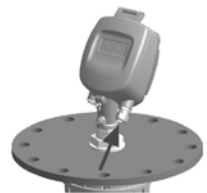

- 3 Insert the cable into the scanner through the cable gland and entry opening.

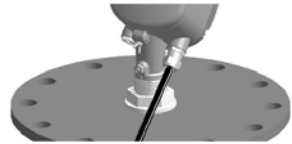

- 4 Remove approximately 10cm (4 inches) of the cable mantle and strip approximately 1cm (0.4 inches) the edge of each conductor.

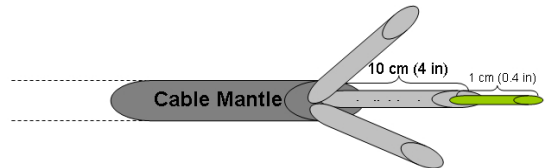

- 5 Open the terminal block screws located inside the scanner housing using a thin flat (A3/32") screwdriver. Insert the wire edges into the terminals according to the wiring plan detailed next, and fasten the terminal screws. Gently pull the wires to ensure they are securely connected.

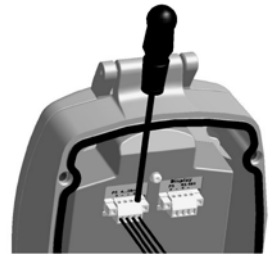

- 6 Terminal block wiring plan.  
The tables below describe the connections.  
Refer to the following Local Connection and Multi-Drop Connection drawings for details.

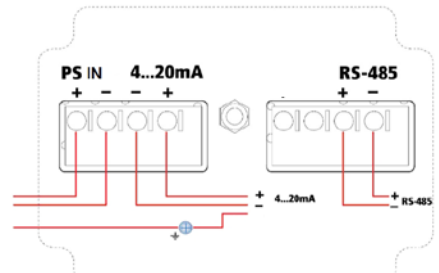

Left Connector	
Ports	Description
PS IN + -	Feed in power supply 20 – 32 VDC
4...20mA - +	4 – 20mA / HART Communications terminals

Right Connector	
Ports	Description
RS-485 + -	RS-485 / Modbus RTU Communications terminals

- 7 Connect the external ground terminal with potential equalization to the external ground terminal of the scanner, located as shown.

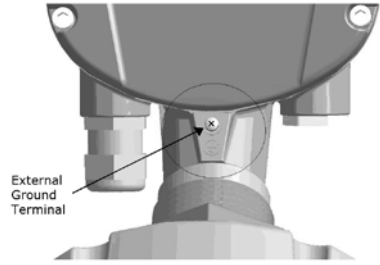

- i** An internal cable grounding connection is also possible using the inner connection as shown.

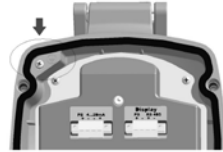

- 8 Tighten the compression nut over the cable gland entry opening. Verify that the sealing ring completely wraps the cable.



**IMPORTANT:** Gland compression nut tightening provides good sealing. It is necessary for the scanner to maintain IP67 requirements, and for extended scanner lifetime.

- 9 Attach the rear panel back to position at the rear of the scanner housing and tighten the four screws to secure it in place, using a 4mm hex key.  
The RL is ready for configuration.

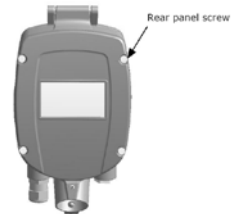

**IMPORTANT:** Use direct connection between the scanners and the plant (PLC/SCADA).

**IMPORTANT:** For a remote connection, use the 3DLinkPro remote connection module or a local PC/Laptop computer as detailed in the following drawing.

**CAUTION:** Do not connect power supply to the 4-20mA or to the RS485 ports. The RL is not a loop powered device but a 4W device.



**WARNING:** The 4...20mA / HART lines should NOT be connected using multidrop.

---

## 4 Configuration





### 4.1 Local User Interface

Configuration and adjustment of the RL is done from the keypad on the device and as an option, it is possible to connect the RL to the 3DLevelManager configuration software.

#### The RL User Interface





The user interface includes a 4-lines LCD display and the four keys located on the front side of the device, marked ESC, +, - and E.

Key functions are as follows:

-  Navigates back within a function menu.  
Continuous 3 second press exits to the default screen.
-  Navigates upwards in the navigation list.  
Navigates right within a function.
-  Navigates downwards in the navigation list.  
Navigates left within a function.
-  Navigates to the right when within a function group.  
Stores a value once configured.



The following, simultaneous key-press combinations perform special functions as follows:

-  Increases / decreases the LCD display intensity.
-  Press and hold the  button, then use the  or  buttons to increase or decrease the intensity of the display.

#### Operating menu

The operating menu consists of two levels:

- **Function groups:** The scanner functions are organized groups. Available function groups are: Output Settings, Display Settings, Device Info and Device Reset.



- **Functions:** Each function group consists of one or more functions. The functions may perform different actions or modify scanner setting parameters. Numerical values can be entered, and parameters can be selected and saved.

## 4.2 Switching on the scanner

Once the RL is connected to the power supply and switched on, it initializes a self-test which lasts for approximately 30 seconds. When the initialization is complete, the following content is displayed allowing selecting a language and distance units:

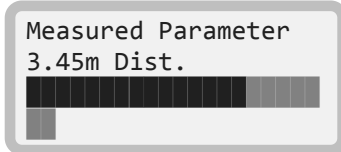
<p>① The unit is turned on and is initializing for about 30 seconds, during which the display remains blank.</p>	
<p>② The version screen appears: Model: RL FW Ver: Firmware version HW Ver: Hardware version</p>	<pre>Init. Please wait... RL2000 FW Ver: 04.01.00 HW Ver: 020</pre>
<p>③ Once the startup process is complete, the following screen appears showing the current distance measurement.</p> <p>The forth line displays the scanner tag name. By default, when the name has not been configured yet, this line remains empty.</p> <p>Press <b>[E]</b> to return to the Main Menu. Press <b>[ESC]</b> for 3 seconds to switch to the basic measurement screen.</p>	<pre>Measured Parameter 3.45m Dist.</pre> 

## 4.3 Main Menu

<p>① Press <b>[E]</b> to enter the Main Menu.</p> <p>Scroll up and down using the <b>[↑]</b> and <b>[↓]</b> keys to select the type and press <b>[E]</b> to enter the selected sub menu.</p>	<pre>Main Menu -&gt;Basic Settings Output Settings Display setting False Echoes Map Device Info Device Reset</pre>
----------------------------------------------------------------------------------------------------------------------------------------------------------------------------------------------	--------------------------------------------------------------------------------------------------------------------

## 4.4 Basic Configuration

Prior to RL configuration, verify that you have silo dimensions and scanner positioning in relation to the center of the vessel.

<p>1 Main Menu appears automatically after power reset, otherwise press <b>E</b> to enter the Main Menu.</p> <p>Scroll to Basic Settings using the <b>←</b> key and press <b>E</b>.</p>	<p>Main Menu →<b>Basic Settings</b> Output Settings Display setting</p>
<p>2 Set the Distance Units.</p> <p>Use the <b>↓</b> and <b>←</b> keys to select the type.</p> <p>Press <b>E</b> to select and move to next parameter.</p> <p>Available options are: m, cm, mm, inch, ft</p>	<p>Distance Unit →<b>m</b> cm mm</p>
<p>3 Set the Vessel Type.</p> <p>Use the <b>↓</b> and <b>←</b> keys to select the type.</p> <p>Press <b>E</b> to move to the next parameter.</p> <p>Go to Step <b>16</b> to configure Rectangular vessel.</p>	<p>Vessel Type →<b>Cylindrical</b> Rectangular</p>
<p>4 Press <b>E</b> to enter the Main Menu.</p> <p>Scroll to Basic Settings using the <b>←</b> key and press <b>E</b>.</p>	<p>Main Menu →<b>Output Settings</b> Display setting Device info</p>
<p>5 Set the Vessel Height.</p> <p>Use the <b>←</b> key to switch between the digits. Use the <b>↓</b> key to modify each digit.</p> <p>Press <b>E</b> to move to next parameter.</p>	<p>Vessel Height <b><u>20.000</u>m</b></p>
<p>6 Set the Vessel Type.</p> <p>Use the <b>↓</b> and <b>←</b> keys to select the type.</p> <p>Press <b>E</b> to move to the next parameter.</p> <p>Go to Step <b>13</b> to configure Rectangular vessel.</p>	<p>Vessel Type →<b>Cylindrical</b> Rectangular</p>

<p><b>7</b> Set the Vessel Diameter.          Use the <input type="checkbox"/> key to switch between the digits. Use the <input type="checkbox"/> key to modify each digit.          Press <input type="checkbox"/> to move to next parameter.</p>	<p>Vessel Diameter  <u>10.000m</u></p>
<p><b>8</b> Set the Scanner Height from vessel bottom          Use the <input type="checkbox"/> key to switch between the digits. Use the <input type="checkbox"/> key to modify each digit.          Press <input type="checkbox"/> to move to next parameter.</p>	<p>Scanner Height  <u>20.000m</u></p>
<p><b>9</b> Set the distance of the scanner from the vessel center.          Use the <input type="checkbox"/> key to switch between the digits. Use the <input type="checkbox"/> key to modify each digit.          Press <input type="checkbox"/> to move to next parameter.</p>	<p>Scanner Center Dist.  <u>00.000m</u></p>
<p><b>10</b> Set the Full Calibration distance measured from the scanner position and defines the 100% (20mA output).          Use the <input type="checkbox"/> key to switch between the digits. Use the <input type="checkbox"/> key to modify each digit.          Press <input type="checkbox"/> to move to next parameter.</p>	<p>Full Calibration  <u>00.500m</u></p>
<p><b>11</b> Set the Empty Calibration distance measured from the scanner position and defines the 0% (4mA output).          Use the <input type="checkbox"/> key to switch between the digits. Use the <input type="checkbox"/> key to modify each digit.          Press <input type="checkbox"/> to move to next parameter.</p>	<p>Empty Calibration  <u>20.000m</u></p>
<p><b>12</b> Set the Process Condition          Use the <input type="checkbox"/> and <input type="checkbox"/> keys to select the type.          Press <input type="checkbox"/> to return to the main menu.  <b>NOTE:</b> Always work with Standard Process Condition. For other conditions select accordingly.</p>	<p>Process Condition          Slow          →<u>Standard</u>          Fast          Very Fast</p>

When configuring a rectangular vessel, the settings are:

<p><b>13</b> Set the Vessel Type. Use the <b>+</b> and <b>-</b> keys to select the type. Press <b>E</b> to move to the next parameter.</p>	<p>Vessel Type <b>Cylindrical</b> →<b>Rectangular</b></p>
<p><b>14</b> Set the Vessel Width (X). Use the <b>-</b> key to switch between the digits. Use the <b>+</b> key to modify each digit. Press <b>E</b> to move to next parameter.</p>	<p>Vessel X Size <b><u>10.000m</u></b></p>
<p><b>15</b> Set the Vessel Length (Y). Use the <b>-</b> key to switch between the digits. Use the <b>+</b> key to modify each digit. Press <b>E</b> to move to next parameter.</p>	<p>Vessel Y Size <b><u>10.000m</u></b></p>
<p><b>16</b> Set the Scanner Height from vessel bottom. Use the <b>-</b> key to switch between the digits. Use the <b>+</b> key to modify each digit. Press <b>E</b> to move to next parameter.</p>	<p>Scanner Height <b><u>20.000m</u></b></p>
<p><b>17</b> Set the distance of the scanner from the vessel center on the Width axis. Use the <b>-</b> key to switch between the digits. Use the <b>+</b> key to modify each digit. Press <b>E</b> to move to next parameter. <i>Note: Scanner X Position cannot be bigger than Half the Vessel X Size</i></p>	<p>Scanner X Position <b><u>+00.000m</u></b></p>
<p><b>18</b> Set the distance of the scanner from the vessel center on the Length axis. Use the <b>-</b> key to switch between the digits. Use the <b>+</b> key to modify each digit. Press <b>E</b> to move to next parameter. Go back to step <b>10</b> <i>Note: Scanner Y Position cannot be bigger than Half the Vessel Y Size</i></p>	<p>Scanner Y Position <b><u>+00.000m</u></b></p>

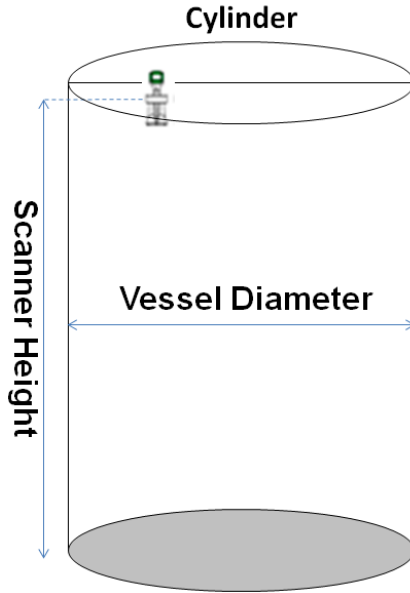

*Cylindrical vessel configuration*

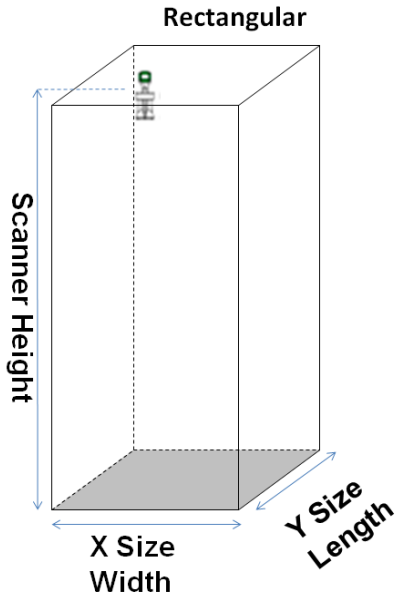

*Rectangular vessel configuration*

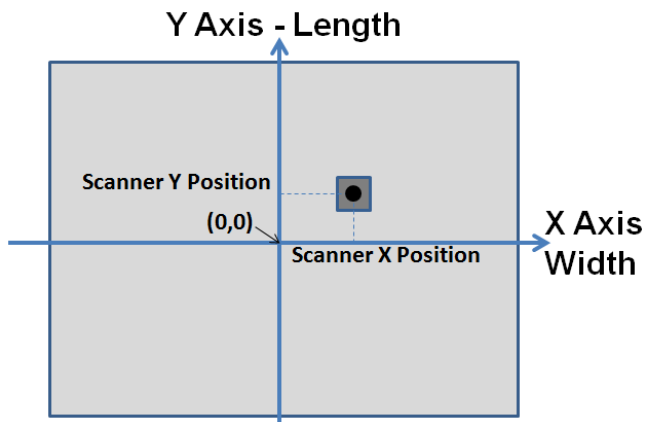

Scanner positioning in rectangular vessel

## 4.5 Output Settings

This function defines the scanner Polling Address, and further to perform Current Simulation. Navigate down at the Main Menu screen using the  $\downarrow$  key, select the **Output Settings** option and press  $\rightarrow$  to enter the Output settings menu.

<p>① The first screen of <b>Output Settings</b> allows setting the scanner polling address.</p> <p>Set the proper <b>Polling Address</b> using the <math>\uparrow</math> / <math>\downarrow</math> keys, and press <math>\rightarrow</math> to proceed.</p> <p>Exiting this menu with the <math>\left[ESC\right]</math> automatically switches to the main menu.</p>	<p>Polling Address</p> <p><u>00</u></p>
<p>② When needed, it is possible to enter the scanner into simulation mode, there are four options: Simulation Off, Percentage Simulation and Current Simulation. Navigation is done with the <math>\uparrow</math> / <math>\downarrow</math> keys, press <math>\rightarrow</math> to proceed.</p>	<p>Simulation</p> <p><math>\rightarrow</math>sim. Off</p> <p>sim. Percent</p> <p>sim. Current</p>
<p>③ Percentage simulation allows setting the output current in percentage between 0.00 to 100.00%.</p> <p>Set the volume using the <math>\uparrow</math> and <math>\downarrow</math> keys, and press <math>\rightarrow</math> to proceed.</p> <p>If the value exceeds 100%, the scanner will alert that the max value is 100%.</p>	<p>Simulation value</p> <p><u>000.00%</u></p>

<p>④ Current simulation allows setting the output current between 4.00 to 20.00mA. Set the current using the <b>+</b> / <b>-</b> keys, and press <b>E</b> to proceed.</p> <p>If the value exceeds 20mA, the scanner will alert that the max value is 20mA.</p>	<div style="border: 1px solid gray; border-radius: 10px; padding: 10px; background-color: #f0f0f0;"> <p>Simulation value <b>04.00mA</b></p> </div>
<p>⑤ After simulation has been selected, on the display there is an indication for Output Current <b>In Process...</b>, following that, the display will show the calculated current.</p> <p>Press <b>E</b> to set a different value, or <b>ESC</b> to go back to the main screen.</p>	<div style="border: 1px solid gray; border-radius: 10px; padding: 10px; background-color: #f0f0f0;"> <p>output current <b>05.60mA</b></p> </div>











## 4.6 Display Setting

This menu allows setting a Tag Name and values to display on the screen.

<p>① At the Main Menu, navigate down using the <b>-</b> key to select <b>Display Settings</b>, and Press <b>E</b> to proceed.</p>	<div style="border: 1px solid gray; border-radius: 10px; padding: 10px; background-color: #f0f0f0;"> <p>Main Menu Basic Settings Output Settings →<b>Display Settings</b></p> </div>
<p>② Set the Tag name for the current scanner. Switch between the digits using the <b>-</b> key and modify the selected digit using the <b>+</b> keys. Press <b>E</b> to store the option. The display will switch to the <b>Displayed Parameters</b> menu.</p>	<div style="border: 1px solid gray; border-radius: 10px; padding: 10px; background-color: #f0f0f0;"> <p>Tag Name  <b>test</b></p> </div>
<p>③ Navigate up/down the menu using the <b>+</b> / <b>-</b> keys, and Press <b>E</b> to select the desired option. The following functions set the displayed measurement units for Distance, Level, Volume, Analog Output, and SNR.</p>	<div style="border: 1px solid gray; border-radius: 10px; padding: 10px; background-color: #f0f0f0;"> <p>Displayed Parameters →<b>Distance</b> Level Percent</p> </div>



## 4.7 False Echo Mapping

This menu allows false echo mapping from the scanner's mounting position to the material.

<p>1 From the Main Menu scroll down to False Echoes Map using the  key and press .</p>	<p>Main Menu Device Reset Basic Settings →False Echoes Map</p>
<p>2 To perform false echoes mapping use the  and  keys to select the option Add to Map. Press  to move to the next parameter.</p>	<p>False Echoes Map Reset →Add To Map</p>
<p>3 Set the False Echoes Mapping distance from scanner position up to 1m above material or silo bottom. Use the  key to switch between the digits. Use the  key to modify each digit. Press  to move to next parameter.</p>	<p>False Echoes Range <u>00.000</u>m</p>
<p>4 To confirm false echoes mapping operation select the Yes option and press . Press  to move to next parameter.</p>	<p>Approve Mapping →Yes No</p>

## 4.8 Device Info

This function allows setting a Tag Name for the current scanner.

<p>1 At the Main Menu, navigate down using the  key to select <b>Display Settings</b>, and Press  to proceed.</p>	<p>Main Menu Display Settings False Echoes Map →Device Info</p>
<p>2 The screen displays the scanner Serial Number. This is a read-only identifier which is unique to each scanner. Press  to proceed.</p>	<p>Serial Number  <b>709001234</b></p>



<p>③ The screen displays the Software Version of the scanner. Press <b>E</b> to proceed.</p>	<p>Software Version</p> <p><b>04.00.164</b></p>
<p>④ The screen displays the Firmware Version of the scanner. Press <b>E</b> to proceed.</p>	<p>HW Version</p> <p><b>018</b></p>
<p>⑤ The screen displays the Device Type: RL Press <b>E</b> to exit and switch back to the Main Menu.</p>	<p>Device Type</p> <p>RL2000</p>

## 4.9 Device Reset

This function allows selection of different reset options: Reset, Reset to Factory settings and Reset to Lab settings. Use with caution!

<p>① At the Main Menu, navigate down using the <b>□</b> key to select <b>Device Reset</b>, and Press <b>E</b> to proceed.</p>	<p>Main Menu</p> <p>False Echoes Map</p> <p>Device Info</p> <p>→Device Reset</p>
<p>② The Reset menu allows selection of the required Reset option.</p> <p>The <b>Reset</b> option brings the scanner to power-up mode and clears measurements.</p> <p>The <b>Reset to Factory</b> option will reset all parameters to their default values as well as performing the <b>Reset</b> option.</p> <p>Select the desired Reset option using the <b>□</b> key and press <b>E</b> to proceed.</p>	<p>Reset</p> <p>→Reset</p> <p>Reset to Factory</p>
<p>③ On selecting Reset or Reset to Factory, a confirmation request screen appears.</p> <p>Select <b>Yes?</b> to proceed with the reset and restart process, or <b>No?</b> to cancel reset. Press <b>E</b> to proceed and go back to the main menu.</p>	<p>Reset the device?</p> <p>→Yes?</p> <p>No?</p>

---

## 5 Different Connection Methods

Using the 3DLevelManager for communicating with the RL allows the user to choose several communication types: RS-485, HART, GSM, GPRS and TCP/IP, for more information and details regarding the communications, refer to the *APM 3DLevelManger Software Instructions manual*.

### 5.1 4-20mA Connection

The RL outputs the % of Volume as set in the configuration and between the Full and Empty calibration levels. The 4-20mA current output is available through ports 3 and 4 of the left green connector (as shown in the drawing to the right). Ports 3 and 4 are the negative and positive poles, respectively.

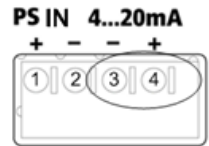

The 4...20mA line is connected directly from the scanner mounted on the vessel to the PLC/DCS/Display or any other device (as shown below).



**IMPORTANT:** This type of connection is active and not passive, hence the RL is the active module and the PLC should be the passive module.



### 5.2 HART Communication

The RL supports HART protocol over the 4-20mA wires. By connecting a 250 Ohm resistor on one of the wires and a HART modem and communication to and from the scanner can be established from the 3DLevelManager software.

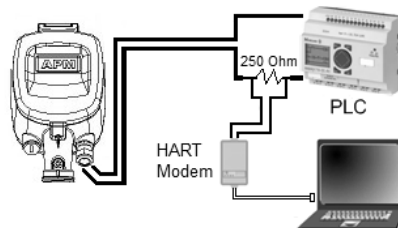

## 5.3 RS-485 Communication

The 3DLevelScanner includes an RS-485 communication port. This type of connection allows a computer to communicate with the scanner. It also allows a multiple scanner connection on the same RS-485 bus and communication with all scanners using a single connection to the computer running the software.

In both single or multi scanner connection, it is required to use an appropriate cable rated for RS-485, the cable should be of twisted pair, has 120 Ohm impedance and shielded. The total length of the cable should not reach 1000m (3280ft).

In case of a multi scanner connection, all scanners must be connected in parallel mode in the RS-485 ports. Hence, all the '+' (positive) ports of the RS485 should commonly be connected and all the '-' (negative) ports of the RS-485 should be connected commonly. The connection must be of Daisy-Chain type and have at each of the far ends of the chain 120 Ohm resistor (such resistor is provided with the scanner).

Each Scanner must be configured with a different polling address.

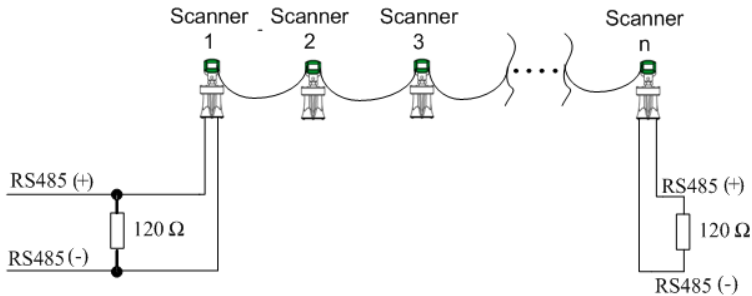

## 5.4 Communication using the 3DLinkPro

In both single and multiple scanner installation, the RL can be connected to a GSM/GPRS modem in order to transfer the data over the cellular network. The 3DLinkPro should be connected on the RS-485 bus as any of the scanners, including cable and resistors as needed. For further details on wiring and establishing a connection, refer to the *APM 3DLinkPro manual* and to the *3DLevelManager Software Instructions manual*.



**NOTE:** In such communication mode, only one computer running the 3DLevelManager software can be connected to the scanners.

## 5.5 TCP/IP Communication

The RS-485 bus can be converted to TCP/IP communication. TCP/IP to RS-485 converter installation should be done as with any scanner, including the resistors and daisy-chain considerations.



**NOTE:** Consult with APM Technical Support team for assistance on the proper TCP/IP converter to use.

## Appendix A: Accessories

### Installation flanges

The following flanges are available from APM.

#### Flange type DN200

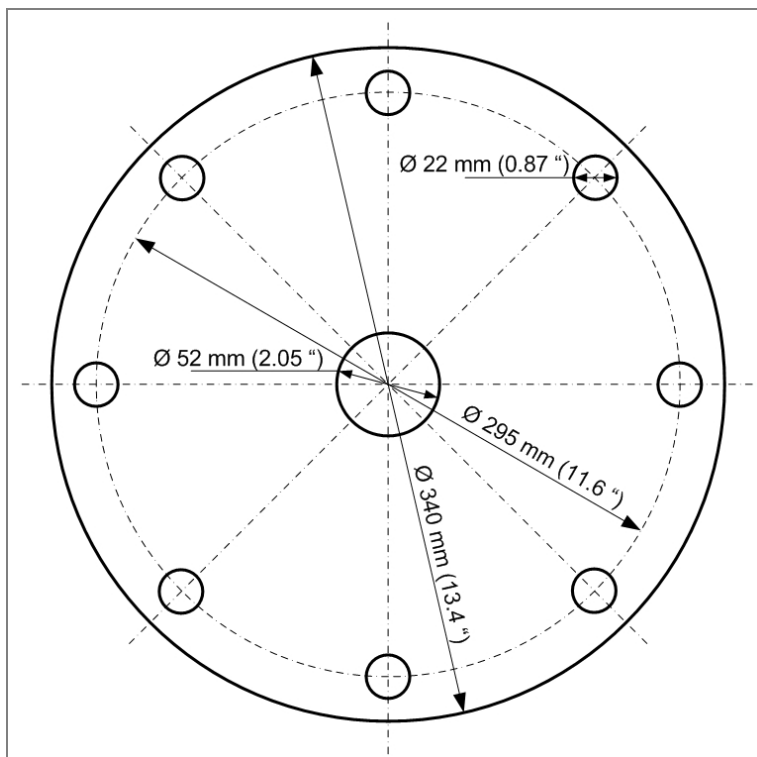

Flange thickness: 6.5mm (0.25").

## Flange type DN250

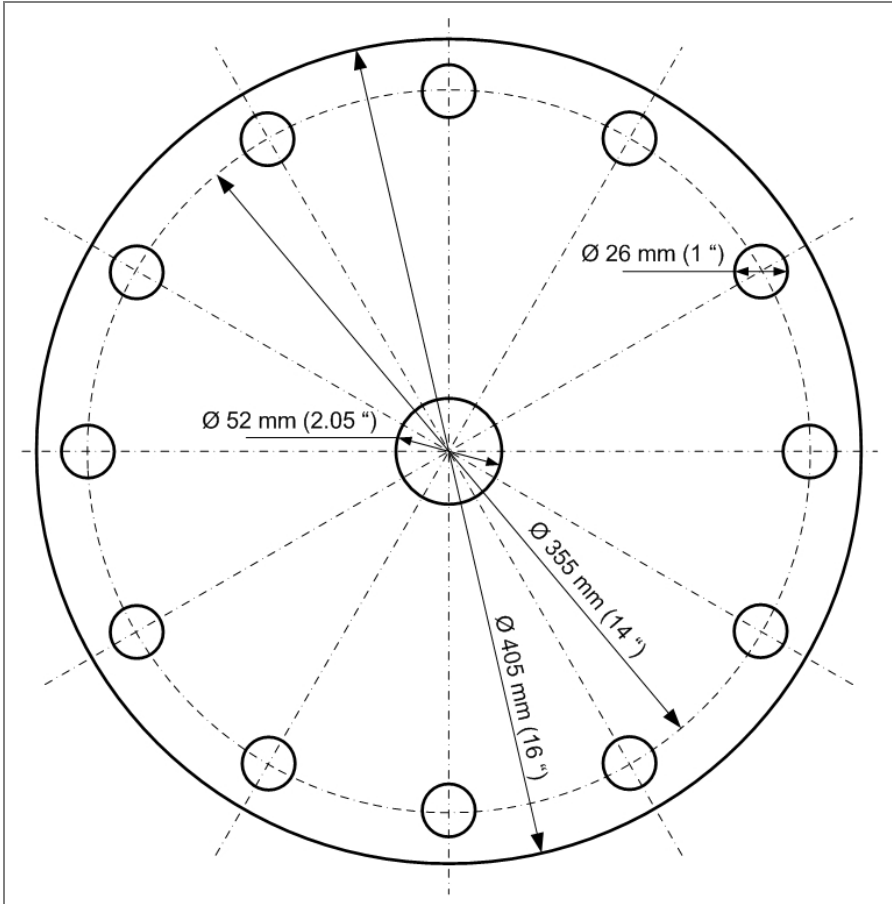

Flange thickness: 6.5mm (0.25").

### Flange preparation and installation guidelines

- The transducer case must fit in the hole in the vessel. If this cannot be reached, use alternative solutions such as neck extension or lowering the scanner inside the vessel.
- The widest part of the scanner is the transducers case: 193.3mm (7.61")
- Insert the flange onto the neck tube
- Tighten the nut to the neck thread using an 18" adjustable wrench
- Note: The diameter of the hole in the center of the flange center is 52mm (2.1")

## Neck Extensions

The purpose of using the neck extensions is to lower the scanner body below obstructions, such as standpipes, support beams or other construction which might block the acoustic signals.

Neck extensions are available in 2 sizes:

- 30cm (11.81")
- 50cm (19.68")

The neck extension must be purchased with a compatible scanner. An adjusted antennas cable length is manufactured with the scanner and is compatible with the required neck extension.



**NOTE:** When using the neck extension, the measurements are referenced to the top part of the scanner body.

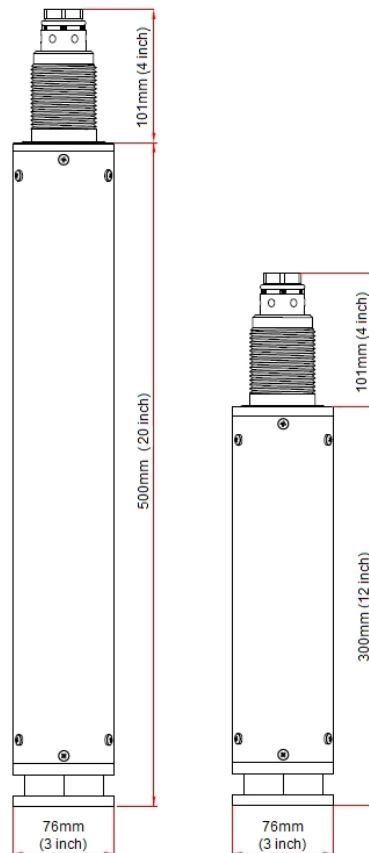

## Head-Body separation

The head body separation solution allows installing the body inside the vessel and the head in an external location where it is easy to maintain and reach.

Head-Body Separators are available in 2 sizes:

- 3m (9.85ft)
- 10m (32.8ft)

Head-Body separation dimensions:

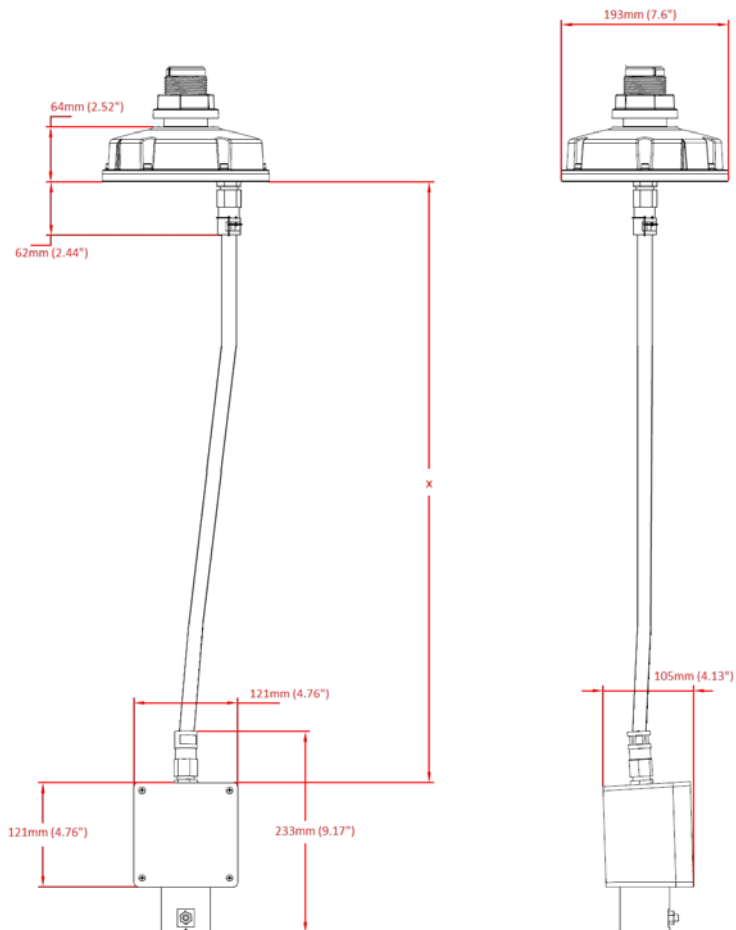

## Cable Extension

APM provides solutions to extend the standard scanner's antenna cable with additional lengths, currently available 30cm, 50cm, 1m and 3m.

The cable extension is provided with an enclosure to seal the connectors.

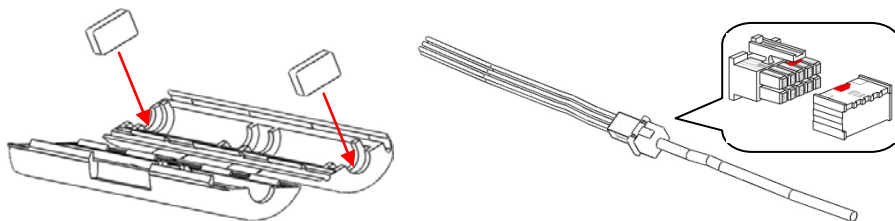

## Cable Glands

The RL™ shipped with one M20 cable gland and one M20 Blind plug.

When ordering RL with option N under the 'Cable Entry / Plug Connection' section (field V in the Pricelist), it is supplied with accessory kit that includes:

- 1 x M20 Cable Gland
- 2 x NPT ½" adaptor

The provided glands and accessory kit will allow the installer to use any combination as he sees fit.

The available options are:

- Using one Gland and one blind
- Using two glands – unscrew the blind and attached the M20 gland
- Using conduits or ½" glands by unscrewing the existing gland or blind, attaching the NPT ½" and connecting the conduit or gland to the adaptor this can be done using one or both cable entries



*M20 Blind Gland*



*M20 Cable Gland*



*NPT ½" Adaptor*



---

## Appendix B: Maintenance

### Preventive maintenance procedure

APM Recommends the following periodical maintenance procedure for keeping the scanner in proper operating conditions and preventing unnecessary malfunctioning which may be caused by environmental factors during time:

- Clean the interior part of the antennas (see details bellow)
- Visually check and ensure the communication and power cables are in good condition and are not damaged
- Check and ensure proper sealing of cable entry openings
- Open the rear side of the scanner head and ensure absence of wetness

Antenna cleaning guidelines:

- Use a brush or wet cloth for the purpose of cleaning
- Disconnect power to the scanner
- Disassemble the flange and carefully pull out the entire scanner
- As necessary, water can be used for cleaning
- Avoid usage of sharp tools such as screwdrivers for cleaning. Such tools may damage the membranes.

### Preventive maintenance frequency

The frequency of the maintenance procedure is subject to the conditions and the type of material stored in the vessel. In the case of materials such as salt, sugar, calcium carbonate etc., treatments should be more frequent.

---

## Appendix C: Recommended Tools

The following tools are recommended for the installation process:

- The site application documents (IPF, AAF), and vessel technical drawings
- A Set of small precision screwdrivers, to be used with the terminal blocks
- 13mm open wrench
- 4mm hex key (preferably with a handle)
- Large adjustable wrench 18"
- Stanley knife, Cutter, Pointed pliers, Isolating tape
- Laser measurement device (or other means to ensure correct positioning and distance to the material)
- RS485 to USB converter, including drivers
- 120Ohm (RS485) and 250Ohm (HART) resistors
- PC/Laptop
- Internet GSM Stick for testing the communications between the installed scanner and the monitoring computer at the center, using the 3DLinkPro.

---

# Appendix D: Specifications

## Technical data

### Materials, non-wetted parts

Housing & Antenna	Painted Aluminum die casting
Inspection window in housing cover	Polycarbonate
Ground terminal	Stainless steel 1.4571/1.4435

### Physical

Weight	5.6kg (12.34 lbs.)
--------	--------------------

### Output variables

Output signal	4...20mA
Resolution	10 $\mu$ A
Current limitation	22mA
Communication	RS485 / ModBus RTU

### Plugs and Cabling

- 1 x cable entry M20x1.5 (cable  $\varnothing$  8...13mm with conductor size of 20 to 24AWG, preferable shielded twisted pairs type cable) assembled on the scanner
- 1 x blind stopper M20x1.5 assembled on the scanner
- Accessory kit with additional M20x1.5 cable gland and 2 x NPT1/2" adaptors

### Display panel

Display	LCD 4 lines x 20 characters
Adjustment elements	4 keys (ESC, +, -, E)

### Load

4-wire sensor	See load diagram bellow
Integration time	0...9999 s, adjustable

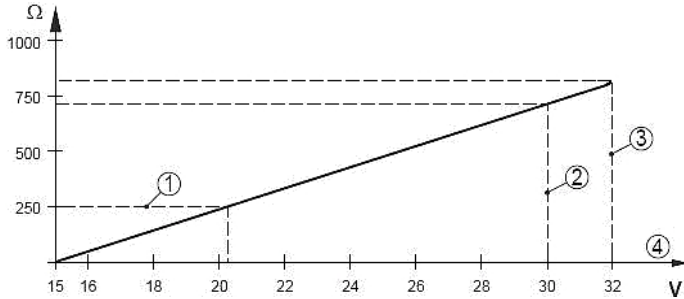

Load Diagram

- 1: HART Load  
 2: Voltage Limit EEx ia device  
 3: Voltage limit non-Ex/Exd ia device  
 4: Supply Voltage

### Ambient conditions

Ambient/storage/transport temperature:	-40...85 °C (-40...+185 °F) [RL™]
Relative humidity	20...85%
Maximum altitude	5,000m (16,400ft)

### Process conditions

Vessel pressure	-0.5...3bar (-50...300 kPa or -7.25...43.5 Psi)
-----------------	-------------------------------------------------

### Process temperature

Measured on the process fitting:	-40...85 °C (-40...+185 °F) [RL™]
Vibration resistance:	Mechanical vibrations of 2g at 5...200 Hz

### Measurement characteristics

Frequency	4.5 kHz
Beam angle with horn antenna	15 degrees
Interval	>2 s
Adjustment time	>3 s

### Power supply – 4-wire device

A safety certified power supply which provides double insulation between the primary and output must be used for powering the unit. The power supply must be a limited power source type with maximum output current 1A and voltage range of 20VDC minimum and 32VDC maximum, and not to be connected to a DC distribution network.

## Power Supply

The power supply will not connect to a DC distribution network.

Supply voltage                      20...32 VDC

Power consumption                max 1.5W

## Electrical protective measures

Protection                          IP 67 according to IEC 60529

## Approvals

**ATEX**    II 1/2D, Ex ibD/iaD 20/21 T110°C  
             II 2G Ex ia/ib IIB T4

**FM**        Intrinsically safe CL I, II, DIV I, GP CDEFG

**CE**        EMC (2004/108/EC) Emission: EN 61326: 1997 (class B)  
             Susceptibility: IEC/EN 61326:1997 + A1:1998 + A2:2001 + A3:2003  
             NSR (73/23/EWG) EN 61010-1: 2001

**FCC**        Conformity to part 15 of the FCC regulations  
             FCC 47 CFR part 15:2007, subpart B, class A

The RL complies with Part 15 of the FCC Rules. Operation is subject to the following two conditions: (1) this device may not cause harmful interference, and (2) this device must accept any interference received, including interference that may cause undesired operation.

## Dimensions

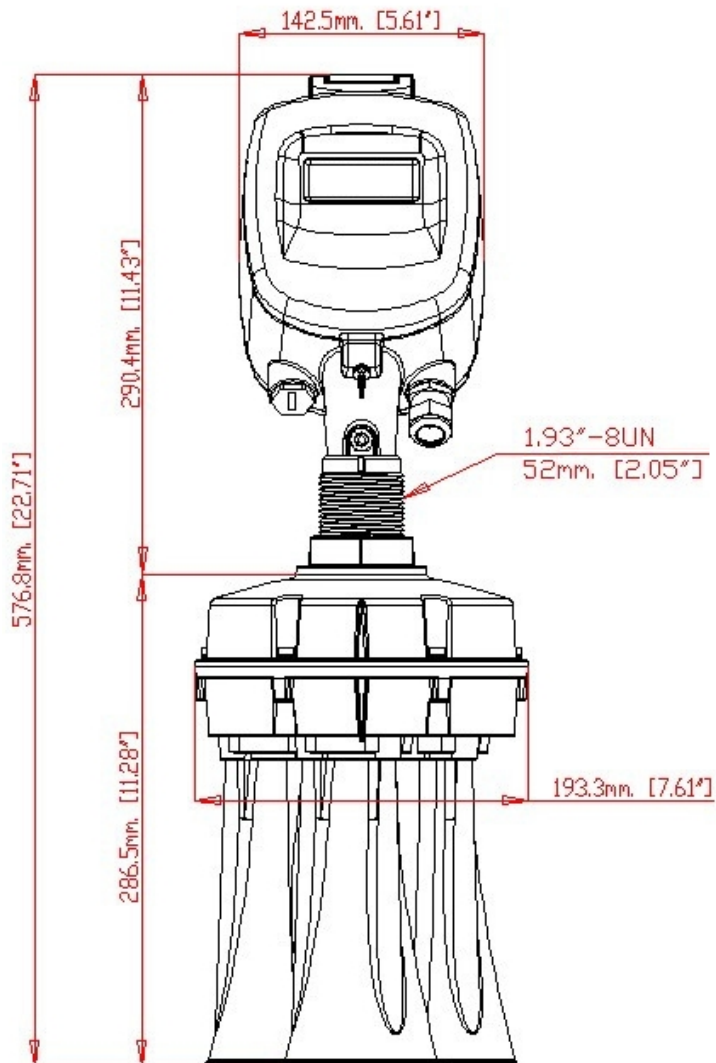

RL dimensions: Front view

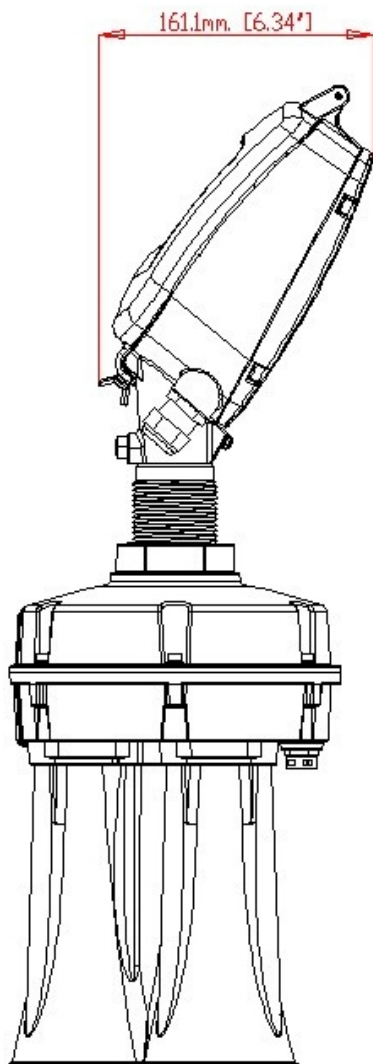

*RL dimensions: Side view*

# RL Operating Instructions

Find all of your level  
measurement needs at:  
[www.binmaster.com](http://www.binmaster.com)

- SmartBob2 weight & cable
- Rotaries
- Capacitance probes
- Vibrating rods
- Diaphragm switches
- Tilt switches
- Ultrasonics
- Radar
- Aeration

Call us for dust & flow detection devices, too!

***BINMASTER***

Shipping Address:  
7201 N. 98th St.  
Lincoln, NE 68507

Mailing Address:  
P.O. Box 29709  
Lincoln, NE 68529

800.278.4241 | 402.434.9102

Fax: 402.434.9133

[www.binmaster.com](http://www.binmaster.com) | [info@binmaster.com](mailto:info@binmaster.com)



Featuring APM  
Automation Solutions  
Ltd Technologies  
(patent pending)